

A COST-EFFICIENT REUSABLE TARGET
PLATFORM THAT REDUCES LIFECYCLE
COSTS WHILE PRESERVING FULL
OPERATIONAL REALISM.

AY[➤]136^C REPLICA [V 1.1]



REAL SHAPE. REAL SIGNATURE.
BUILT FOR SCALE.



The **AY-136^e Replica** is a full-scale target drone engineered to replicate the Shahed-136 threat profile while delivering a cost-effective and operationally flexible alternative to conventional aerial target systems.

The platform addresses a key capability gap in current inventories: the need for a **realistic, full-scale threat surrogate** that **combines affordability, reusability, and mission adaptability** within a single system.



The **AY-136^c Replica** is designed to support a dual-use operational model, enabling its employment across both non-destructive and destructive mission profile.

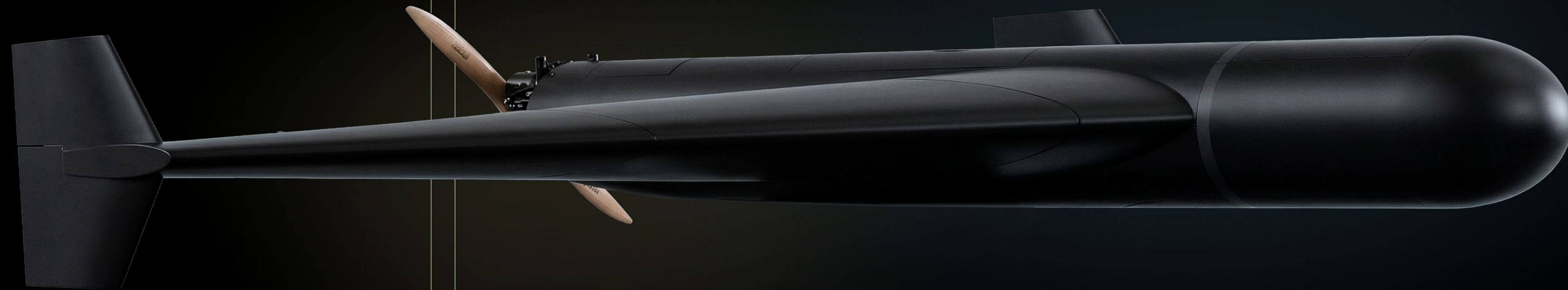

- **Reusable target platform**

For tracking, interception training, and system validation, maximizing asset utilization across multiple sorties.

- **Expendable target (mission-dependent)**

For hard-kill validation, warhead effectiveness, and lethality assessment.

This dual capability allows operators to **rationalize fleet composition**, reducing reliance on separate reusable and expendable target systems.



Use Cases

Scalable. Autonomous. Training-Ready.

- **Air Defence Training & Interception**
 - ↳ SHORAD / VSHORAD / MANPADS engagement training
 - ↳ Fire control solution validation
 - ↳ End-to-end engagement sequence training (detect-track-engage)
 - ↳ Multi-sortie training cycles using reusable target profiles.
- **Hard-Kill Validation & Lethality Testing**
 - ↳ Missile and gun system effectiveness testing
 - ↳ Warhead performance and proximity fuze validation
 - ↳ Terminal phase engagement scenarios
 - ↳ Full-scale impact and destruction analysis.
- **Sensor & System Performance Evaluation**
 - ↳ Radar, EO/IR and RF detection validation
 - ↳ Tracking and classification performance assessment
 - ↳ Signature-based system calibration
 - ↳ Counter-UAS system benchmarking

A single platform enabling both reusable training operations and expendable test scenarios, optimizing cost, realism and operational flexibility. The **AY-136^c Replica** enables a wide range of training, testing and validation activities requiring a full-scale, **high-fidelity loitering munition surrogate**, with the added benefit of **platform reusability** when mission profiles allow.

- **Sensor & System Performance Evaluation**
 - ↳ Radar, EO/IR and RF detection validation
 - ↳ Tracking and classification performance assessment
 - ↳ Signature-based system calibration
 - ↳ Counter-UAS system benchmarking
- **Test & Evaluation Campaigns**
 - ↳ Developmental and operational testing (DT/OT)
 - ↳ System integration trials
 - ↳ Engagement envelope validation
 - ↳ Scenario-based threat replication.
- **Reusable Target Operations**
 - ↳ Non-destructive interception training
 - ↳ Tracking and shadowing missions
 - ↳ Abort / no-fire engagement scenarios
 - ↳ Repeated sortie generation on the same asset.
- **Swarm & Multi-Target Scenarios**
 - ↳ Coordinated multi-drone threat simulation
 - ↳ Saturation attack training
 - ↳ Distributed tracking and engagement exercises

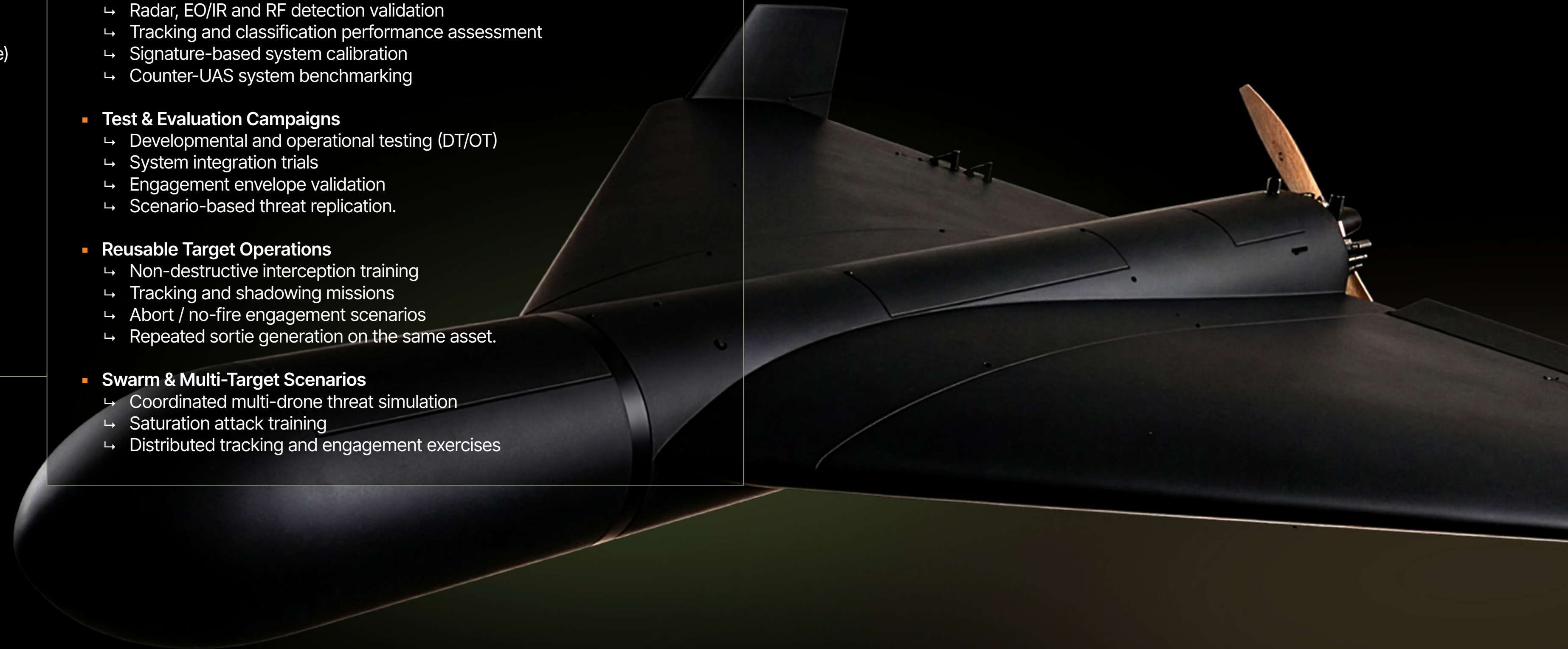

AY>136^C REPLICa

[V 1.1]

Rebooting Aerospace
in the Autonomy age

AURYN[®] AERO

 NATO Capability Class: PROTECTION
NATO Class: I SMALL

TECHNICAL DATASHEET

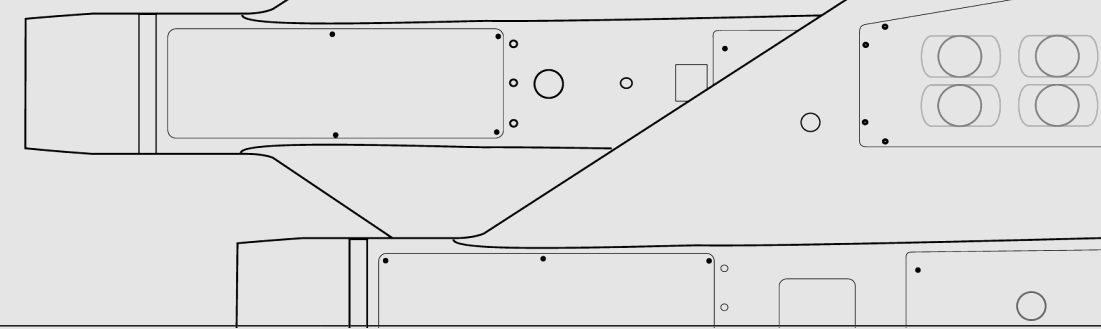

01 / [AIRFRAME] Carbon composite

Wingspan	2.5 m	Lenght	2.8 m
Configuration	Fixed-delta wing loitering type	Landing Gear	Fixed with steering capability

02 / [PERFORMANCE*]

Endurance	4 hrs	Max Range	1000 km
Ceiling	3000 m	Operating Speed	180 kph
Max Speed	200 kph	Dash speed	250 kph
Max Takeoff Weight	80 kg	Payload Capacity	20 kg

03 / [LAUNCH & RECOVERY]

04 / [PROPULSION & SIGNATURE]

Take-Off Method	Take-off from runway / Pneumatic launcher	Engine Type	Two-stroke, four cylinder with optional starter
Take-Off Distance	250 m	Engine Power	23 hp
Landing Method	Conventional / Parachute + Airbag		

05 / [FLIGHT & MISSION]

Flight Modes	Navigation System	Mission Profiles	Swarm Capability
Manual, Assisted, Fully autonomous based on GPS waypoints	GNSS / INS	Waypoints, Loiter, Attack profiles, Custom	Pre-programmed multi-unit Deployment

06 / [OPERATIONAL]

07 / [OPTIONAL CONFIGURATIONS]

Deployment Time	15 mins	RCS Tuning	Lüneburg lenses
Turnaround Time	10 mins	Payload Options	EO/IR, telemetry, decoy systems
High-Frequency Deployment Capability Operational Cost Efficiency		Range Extension Options Swarm Operations	

@2026 ALL RIGHTS RESERVED
OUR PRODUCTS PURCHASES INCLUDE ALL THE NECESSARY DOCUMENTATION, A BULK HOURS OF CUSTOMER TRAINING AND A COMPREHENSIVE AFTER-SALE ASSISTANCE AND PRE-PLANNED MAINTENANCE. CONTACT US TODAY TO BOOK A FLIGHT DEMONSTRATION! THIS PRODUCT, TRADEMARK AND NAME IS UNDER PATENT APPLICATION.
AVAILABLE IN NDAA VERSION FOR US MARKET

NOTE: Specifications are subject to environmental factors, aircraft configurations, and flight mission profile.
* Weather conditions will create variability in performance specifications. For example, strong tailwinds can result in aircraft range that exceeds current advertised product specifications. Similarly, headwinds and other environmental factors can reduce aircraft range below what is currently advertised.
**Release dates vary by payload



Rebooting Aerospace in the Autonomy age

© All Rights Reserved